



# HV WALL FAN

## HIGH-VOLUME WALL FAN

**IP54**

SINGLE PHASE MODELS

**IP55**

THREE PHASE MODELS

**POWERFUL**

AIR FLOW

The HV wall mounted fan is designed to ventilate large buildings where high air volumes are required at low pressure. The fan comes with heavy duty self-closing backdraft shutters to prevent weather ingress when the fan is switched off. They are ideal for warehouses, large workshops, poultry sheds and recreation halls.

- Available in single and three-phase options in 800mm, 1000mm and 1250mm fan diameter sizes.
- Fitted with safety guards.
- Lightweight durable construction using robust galvanised steel.
- Self-closing backdraft shutters to prevent weather ingress when not in use.
- Adjustable motor plate simplifies belt maintenance.
- Fitted with nutserts and grab handles for easy installation.
- Simple and easy to install.
- IP rating: Single phase models: IP54  
Three phase models: IP55

### DIMENSIONS

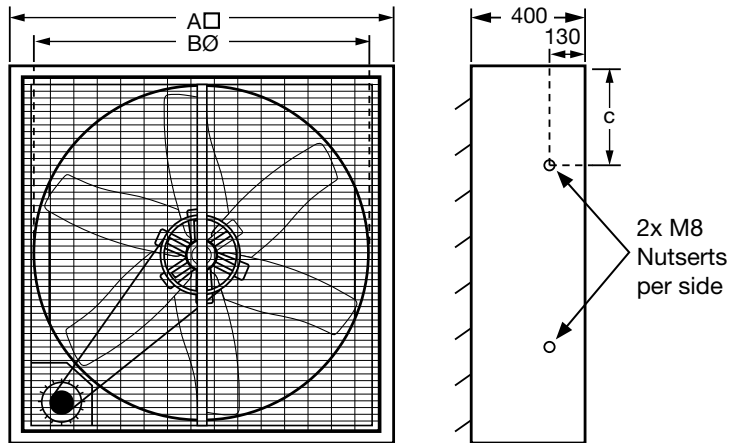

MODEL	A	B	C
HV_080	900	800	270
HV_100	1060	1000	270
HV_125	1380	1250	295

All dimensions in mm

### SPECIFICATIONS

MODEL	FAN SIZE (MM)	VOLTAGE (V)	FREQ (HZ)	POWER (KW)	AIRFLOW (M <sup>3</sup> /HR)	NOISE (dB(A)@3M)	SPEED (RPM)	WEIGHT (KG)
HVE080	800	240	50	0.37	16,000	49	450	42
HVD080	800	415	50	0.37	16,000	49	450	42
HVE100	1000	240	50	0.75	32,000	50	450	60
HVD100	1000	415	50	0.75	32,000	50	450	60
HVE125	1250	240	50	1.1	44,500	55	450	65
HVD125	1250	415	50	1.1	44,500	55	450	65